



BIPARK



PARK PLUS

PARK PLUS:

TEL: 085-161-3333

WEB: WWW.PARKPLUSTH.COM

FACEBOOK: WWW.FACEBOOK.COM/PARKPLUSTH

EMAIL: PARKPLUSTH@GMAIL.COM

**ADDRESS: 46 PUNNAWITEE 30, SUKHUMVIT ROAD,
BANGKOK, THAILAND, 10260**



BIPARK





Bipark 26 is a compact double car stacker that lifts the car smoothly and quickly into position.



The platform has a lift capacity of 2,600 Kg and will accommodate the new generation SUVs, 4-wheel-drive vehicles and low clearance sports cars.

Moreover, the galvanized platform structure is designed to prevent fluids from the upper vehicle dripping down on the lower one.



The overall compactness of the product reduces the space requirements to the barest minimum, and thus allowing several vehicles to be parked in a relatively small space. The pushbutton control panel can be installed in the most convenient position for controlling the lift depending on customer's requirements.

The platform has a front wheel stop bar set at the front edge of the platform.



This photograph clearly shows how compact the platform is and how little space is required by the unit's electro-hydraulic system, the true heart of this machine.

When this platform is raised to maximum height, any type of standard passenger vehicle can be parked underneath,

while still ensuring easy loading and removal of vehicles.





The unique torsion bar locking mechanism - a toothed pinion that is integral to the torsion bar itself and the electromagnetically operated dog - ensure that the platform can be safely stopped at any height, even after departing the highest position.

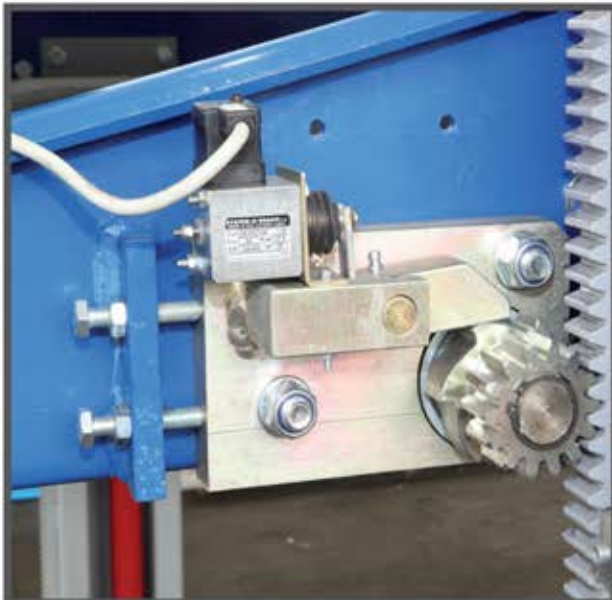



The torsion bar-pinion assembly that engages the rack aligns the platform so that the weight on the platform does not need to be balanced. This allows the car can be parked facing forewords or backwards or to be offset side to side.



The photo, seen from above, shows the platform carriage. This carriage is guided by wheels and molybdenum disulphide reinforced nylon guides. This combination reduces friction between column and carriage and thus lowers the power needed for operation. Moreover, it ensures that the machine remains in good working order, guaranteeing a long lifespan and reducing the need for maintenance. In addition, the unique shape of the column significantly reduces unit dimensions while increasing resistance and stiffness.



The push button control panel has a mushroom-shaped emergency button and a lockable activation key. If several of these units are used side-by-side, the keys can all be the same, or each one can be different, again depending on customer need.

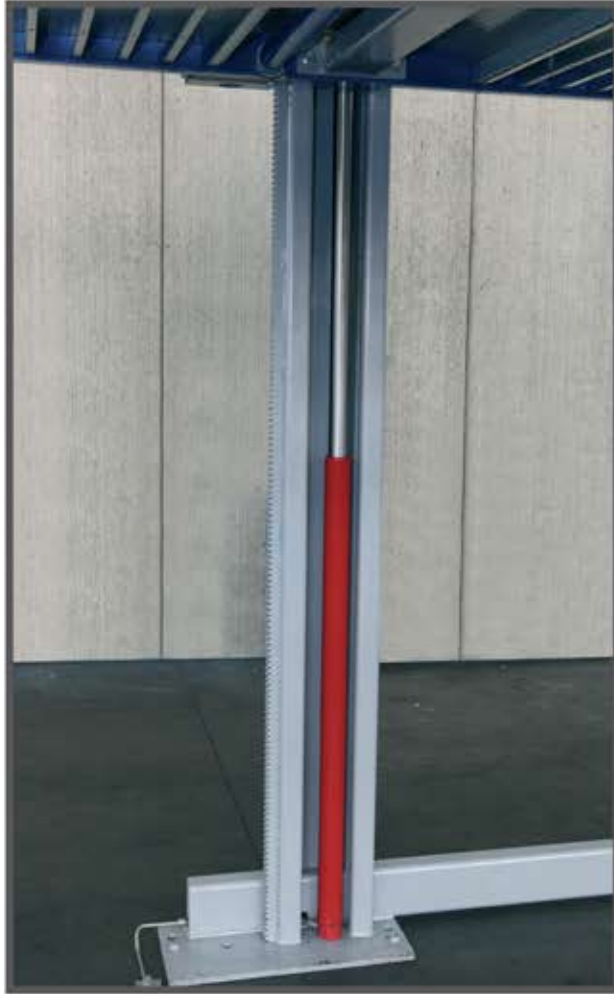

The hydraulic double extension lifting cylinders (RAM - manufactured by O.M.E.R. S.p.A.) permits direct lifting, without any auxiliary aids such as cables or chains.



The compactness of the electro-hydraulic assembly and the electrical panel - located at the top of the left hand column - ensures the utmost efficiency in minimal space, thus ensuring unhindered parking of the car.



The vertical lifting height of the platform is set during the initial installation by means of locking steel plates mounted at the top of the columns, thus guaranteeing safety and

determining the peak lifting height, designed to customer requirements and environment.

BIPARK 26

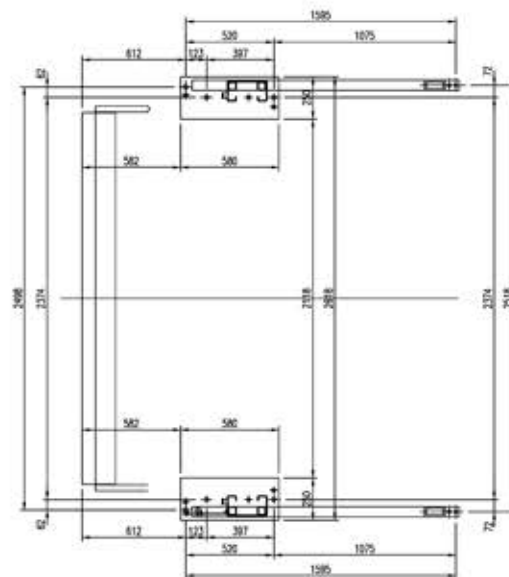
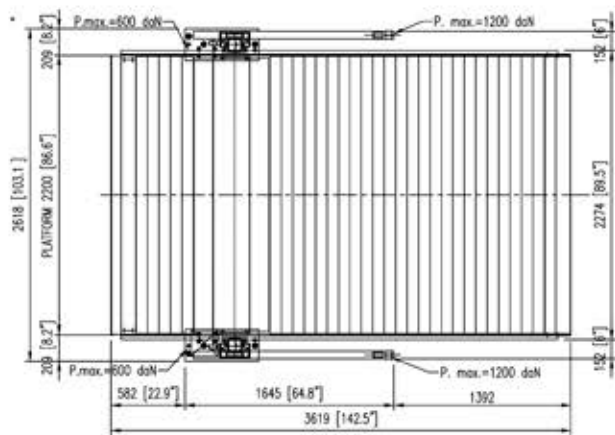
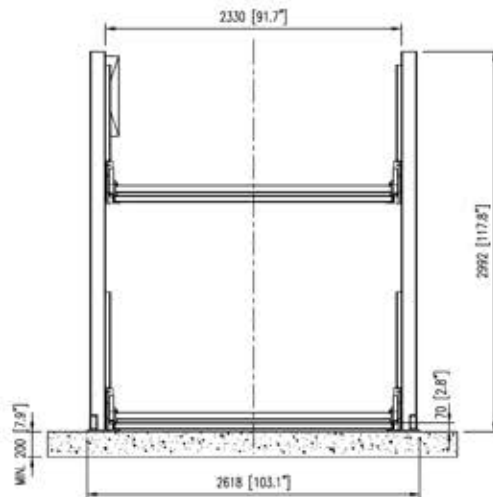
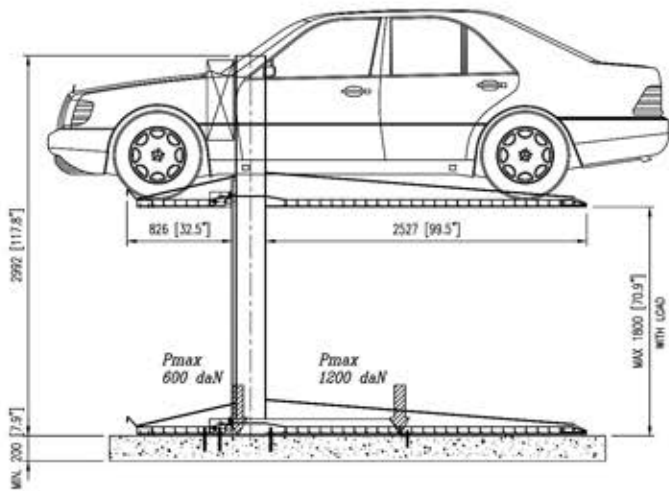

	Capacity	Standard Lifting Height	Max Lifting Height	Standard Platform	Net height	Pit	Power	Speed	Power supply	Standard Weight	Notes
BIPARK 26	2.600 kg	1.850 mm	1.850 mm	2.200x3.619 mm	1.800 mm		1,5 kw	0,04 m/s	400 v / 50 hz	1.050 kg.	
	5.727 lbs	72,8 inch	72,8 inch	86,6x142,5 inch	70,9 inch		2,0 hp	1,6 inch/s	400 v / 50 hz	2.313 lbs	
BIPARK 26 H 21	2.600 kg.	2.100 mm	2.100 mm	2.200x3.619 mm	2.050 mm		1,5 kw	0,03 m/s	400 v / 50 hz	1.100 kg.	
	5.727 lbs	82,7 inch	82,7 inch	86,6x142,5 inch	80,7 inch		2,0 hp	1,2 inch/s	400 v / 50 hz	2.423 lbs	
BIPARK 32	3.200 kg.	2.100 mm	2.100 mm	2.400x3.619 mm	2.050 mm		1,5 kw	0,03 m/s	400 v / 50 hz	1.270 kg.	
	7.048 lbs	82,7 inch	82,7 inch	94,5x142,5 inch	80,7 inch		2,0 hp	1,2 inch/s	400 v / 50 hz	2.797 lbs	

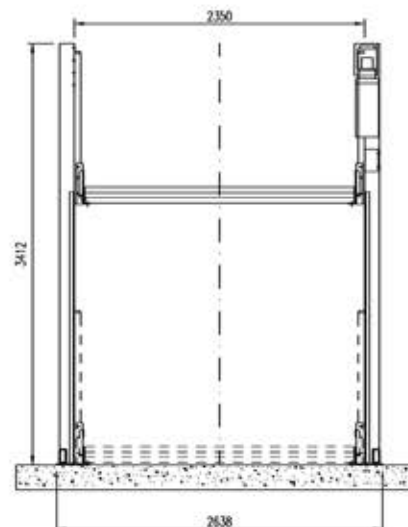
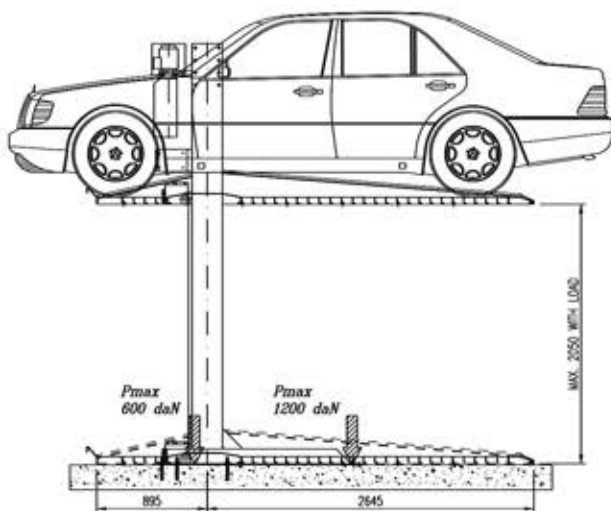
BIPARK 26 H 21

ACCESSORIES

■ STANDARD □ OPTIONAL

DESCRIPTION	BIPARK 26	BIPARK 26 H21	BIPARK 32	NOTES
Standard colours: BLUE RAL 5005 and SILVER RAL 9006	■	■	■	
Nr. 2 columns complete with lifting cylinders	■	■	■	
Nr. 1 standard platform	■	■	■	W 2.200 x L 3.619 mm.
Nr. 1 torsion bar	■	■	■	
Nr. 1 front wheel stop bar	■	■	■	
Nr. 1 "dead man" push-button board	■	■	■	
Nr. 1 hydraulic control unit with motor 1,5KW	■	■	■	
Power Supply: 230-400V/3Ph/50-60Hz	■	■	■	
Adjustable stopping height	■	■	■	
Mechanical and electrical safety devices	■	■	■	
Nylon Package	■	■	■	
Push-button board support	□	□	□	
Waterproof galvanised cover for control unit for outdoor installation	□	□	□	
Waterproof push-button board IP 65	□	□	□	
Top Cover (nr. 2 pieces)	□	□	□	
Flashing light	□	□	□	
Audible warning kit	□	□	□	
Emergency manual pump	□	□	□	
Vehicle Presence Sensor under the Platform	□	□	□	
Vehicle Presence Sensor above the Platform	□	□	□	
Non standard power supply - 220V/1Ph/50-60Hz - 208V/3Ph/60Hz	□	□	□	
Identical Keys for a set of Biparks	□	□	□	
Different keys for a set of Biparks	□	□	□	Max 10 different keys
Hot Galvanised metal finish	□	□	□	Columns, guides, columns connection plate, platform profile, ramp and wheel stop
Wood Pallet for Bipark 26 Structure	□	□	□	
Control Panel Cradle	□	□	□	